

# Comparative Study of various Commercially Available Programs in Slope Stability and Simulation of Dynamic Loading

Tushar Khandelwal<sup>1\*</sup>, Dikshit<sup>2</sup>, P. Thareja<sup>3</sup>, R. K Sharma<sup>4</sup>

<sup>1</sup>PEC, University of Technology, Chandigarh

<sup>2</sup>GMR Airport Developers Ltd., Delhi

<sup>3</sup>Lehmeyer International, Delhi

<sup>4</sup>National Institute of Technology Hamirpur (H.P.), India

## Abstract

Analysis of slope stability is carried out to identify the most critical failure plane so as to minimize the occurrence of slope failures and landslides. It is always needed to give serious consideration before any construction or development is executed to ensure that the designed slopes remain stable. Slope failure can be determined through appropriate measurement of slope stability. In this study C-programming and GEO4 and Plaxis 2D software have been used to determine the factor of safety of the selected slope. Total station surveying has been used to prepare contour maps of the study area using LISCAD. The parameters such as soil cohesion ( $c$ ), angle of internal friction ( $\phi$ ), and unit weight of soil ( $\gamma$ ) have been determined using laboratory experiments. The site is modeled as multilayer so as to simulate real conditions as close as possible. The simulation involving dynamic loading as the site is subjected to mild earthquakes is also incorporated. The study is conducted for a site where the mode of failure is analyzed using Bishop's method and appropriate preventive measure for slope stability is recommended and detailed design is provided.

**Keywords:** slope stability analysis, limit equilibrium methods, software, factor of safety

\*Author for Correspondence E-mail: [khandelwal.tushar@yahoo.com](mailto:khandelwal.tushar@yahoo.com), 9876640951

## INTRODUCTION

Every slope has forces acting on it that tend to disturb its stability. The main force is the self-weight of the soil mass forming the slope, but seepage, seismic activity and external loads are also disturbing forces. A factor of safety is calculated by dividing the forces resisting movement by the forces driving movement. In earthquake-prone areas, the analysis is typically run for static conditions and pseudo-static conditions, where the seismic forces from an earthquake are assumed to add static loads to the analysis.

Slope stability analyses and stabilization require an understanding and evaluation of the processes that govern the behavior of slopes. Once the slip has occurred, a weakness along the slip circle remains, which may then recur at the next monsoon [1–9]. The slope stability

analyses are performed to assess the safe and economic design of human-made or natural slopes (e.g. embankments, road cuts, open-pit mining, excavations, landfills etc.) and the equilibrium conditions. Excellent commercial software like Geo5, Plaxis, Z-soil, etc. have made a powerful viable alternative to the assistance of the geotechnical engineer. The main aim of slope stability analysis are finding endangered areas, investigation of potential failure mechanisms, determination of the slope sensitivity to different triggering mechanisms, designing of optimal slopes with regard to safety, reliability and economics, designing possible remedial measures, e.g. barriers and stabilization [10–22].

## SCOPE AND OBJECTIVE

The concept of layered soil was incorporated in the analysis using Geo4 and PLAXIS which

are the latest development in the field of the geotechnical computations. The study involves analysis for five different cases which are explained later in the chapter 'Analysis' section. Effect of dynamic simulation on the modelled slope of the site surveyed was another key feature in the analysis that brings the study to be seen more practical in real world scenario.

The present study generates a section wise analysis of the slope characteristics and factors of safety. The potential failure surfaces are simulated with dynamic loading and providing the design of suitable remedial measures.

## SITE

Himalayan Mountains have the steepest slopes, and are ideal for the study of slope failures. Due to high seismicity, active tectonics, frequent catastrophic precipitation and wide variety of rock and sediments, slope failures are extreme in mid Himalayan region, The SH 32 Bangana, H.P connecting Una to Hamirpur comprises the main study area. The 85 km stretch transcends the outer and lesser Himalayas (Mid Himalayan tract of H.P).The study area lies between latitudes N 31°36'36" N and longitudes 76°20'19" E.

The average rainfall that it receives monthly during monsoon is 100–200 cm. The site which has been chosen for the purpose of study is as follows:

It is located at a distance of nearly 7.5 km from Una towards Hamirpur on SH 32.

It has the following extent:

Length = 30m

Maximum height = 24m.

This site has visible signs of partial failure from 3m to 30m. The first 3m stretch however does not show any sign of failure. The soil stratum is non-homogenous showing variation within stretches of 8-9 m along the length and height. The Vegetation consists of a dense cover of trees and shrubs.

## SITE INVESTIGATIONS

### Preparation of Contour Maps

The geometry of the profile was drawn using total station survey. The reduced levels, horizontal distance, vertical and horizontal angles were recorded from total station. These are fed as input in the software LISCAD. LISCAD was used to generate contour maps and sections of the site.

Figure 1 show the contour map and Figure 2 shows the cross-section of the most critical site generated using LISCAD. Contour maps obtained were used for the following purposes:

1. Determination of the extent i.e. length and height of the slide.
2. Obtaining cross sections along the length at suitable intervals and the corresponding variations in elevations.
3. Determining horizontal (x) and vertical (y) coordinates of points along the slope.

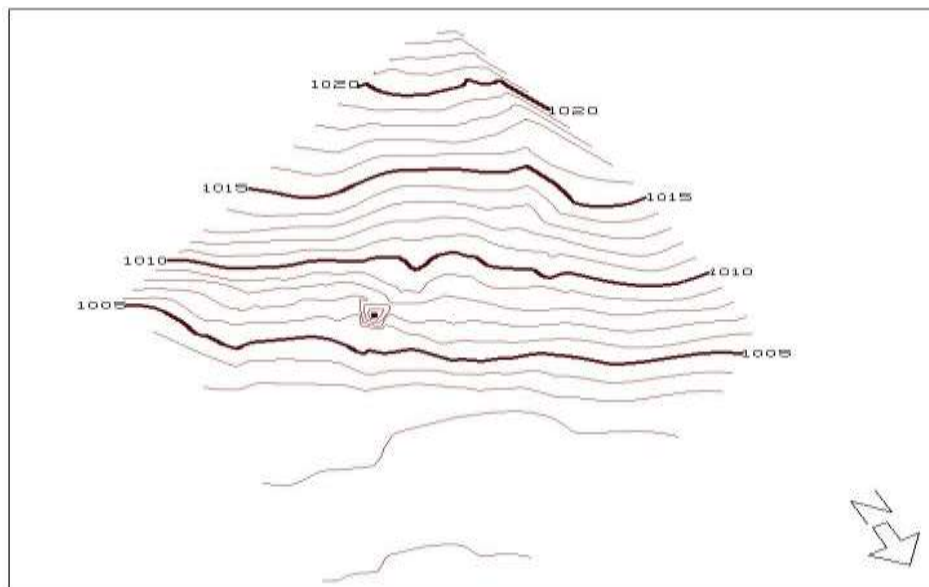

**Fig. 1:** Contour Map of the Site.

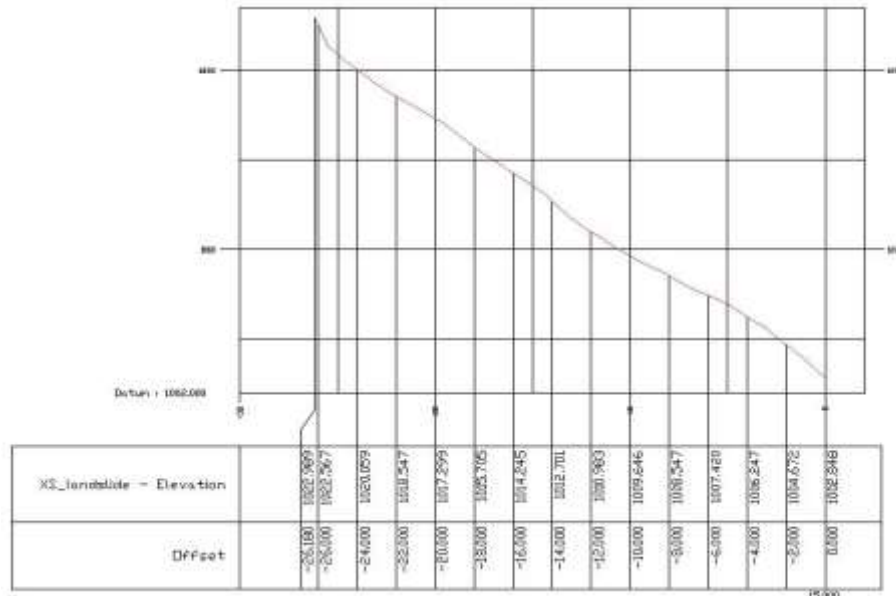

Fig.2: Cross-section of the most Critical Section.

### Geotechnical Investigations

Keeping in view the variation in strata, 3 soil samples were collected from three different heights the sites using core cutters.

Samples were obtained using core cutter and were tested in the laboratory for determination of various soil parameters.

Parameters	Values
Water content (w)	20.29%
Specific gravity (G)	2.51
Unit weight of soil (Y)	18.08kN/cum
Saturated unit weight (Ysat)	19.08kN/cum
Liquid limit	35.776%
Plastic limit	Non Plastic
Optimum moisture content	13.674%
Maximum dry density	1.60KN/cum
Cohesion (c)-Top layer	0 kPa
Angle of internal friction (φ)-Top layer	32.5°
Cohesion (c)-Middle layer	18.61 kPa
Angle of internal friction (φ)-Middle layer	21.8°
Cohesion (c)-Bottom layer	20.80 kPa
Angle of internal friction (φ)-Bottom layer	20.5°

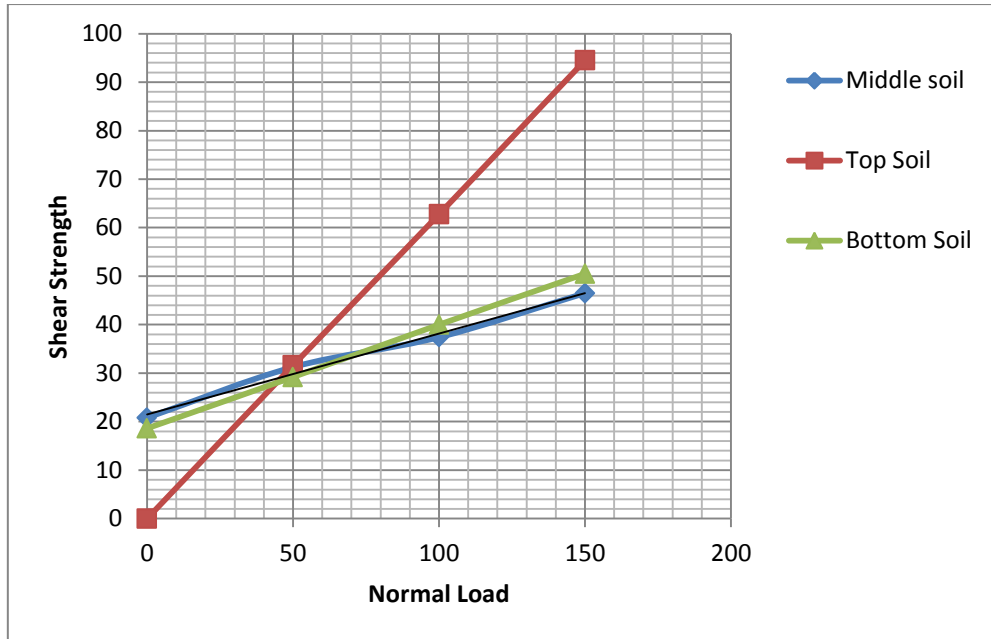

Fig. 3: Graphs from Direct Shear.

## ANALYSIS

**Methods of Analysis:** The stability of a finite slope can be investigated by a number of methods as mentioned below:

1. Culmann's method of planer failure surface.
  2. The Swedish circle method (slip circle method)
  3. The friction circle method
  4. Bishop's method
- Bishop's method has been used for slope stability analysis.

### Bishop's Method

The analysis has been performed using Bishop's method of slices. In this method, the failure section is divided into a series of vertical slices. The slice width is sufficiently small so that the actual shape can be replaced with a trapezoid. It is assumed that the slice weight  $W$  acts through the midpoint of the area. The factor of safety  $F$  is given by:

$$F = \frac{1}{\sum W \sin \alpha} \sum [cb + \tan \phi (W - Ub)] \frac{\sec \alpha}{1 + \frac{\tan \phi \tan \alpha}{F}}$$

where,  $F$  is the Factor of safety;  $w$  is the weight of slice;  $c$  is the cohesion;  $b$  is the width of slice;  $\phi$  is the angle of internal friction and  $U$  is the pore pressure at each slice.

An iterative analysis is necessary to obtain the factor of safety. Since this is a trial and error method, the assumed factor of safety  $F$  is

entered with respect to which the new factor of safety is calculated and the iteration process is continued till the difference between the two values of factor of safety calculated is negligible.

The slope stability analysis was carried out using C-programming as well as GEO4 to calculate the minimum factor of safety at sections at 3m interval each for both the sites.

### Software Used

The software used in the analysis of slopes are:

1. C-Programming
2. Geo 4
3. PLAXIS

### C- Programming

Originally designed as a systems programming language, C has proved to be a powerful and flexible language that can be used for a variety of applications, from business programs to engineering. C is a particularly popular language for personal computer programmers because it is relatively small -- it requires less memory than other languages.

### Analysis Method

This is the approximate method to calculate the coordinate of center of rotation and approximate Factor of safety by assuming that the soil is homogeneously same throughout the profile and slope to be a straight line slope. The method of analysis used by it is Bishop's

Method of analysis. Here it is done at an interval of 3m.

### Minimum Factor of Safety at Different Profiles

The input parameters in the Given C-Program:

1. Input Coordinate of Lower Point, Top Slope Point, Top Point
2. Centre of rotation's X- coordinate
3. No. of slices
4. Bulk density
5. Cohesion, Angle of friction
6. Pore Pressure
7. Factor of Safety
8. Iteration

**Table 1:** Minimum Factor of Safety by C-Program

Cross Sectional Distance	Minimum Factor of Safety
0	1.43
3	1.47
6	1.86
9	1.66
12	1.27
15	1.28
18	1.30
21	1.34
24	1.48
27	1.52
30	1.52

### Introduction to Geo 4

Geo4 is the product of the company 'FINE Ltd' designed to analyze the geotechnical structures. For Windows represents a collection of programs designed to solve a large number of problems commonly encountered in geotechnical engineering. It

includes integrated modules such as Stability of slopes, Reinforced slopes, Nailed slopes, Rock stability, Spread footing, Plates, Beams, Pile Cantilever wall, Abutment, Gravity wall, Gabions, Earth pressure, Sheet piling design, Sheet piling check, Settlement. A wide range of geotechnical problems such as beams on elastic foundations, excavation etc. can be modeled which can be used to study the real behavior of the material in the structure. All programs are available either separately or can be integrated into complex state-of-the-art software handling all essential geotechnical problems.

### Optimization in Geo 4

The optimization procedure searches for the circular slip surface with the lowest factor of safety  $F_s$ . The circular surface is determined by three points: two points on the terrain surface and one point inside the soil body. Each point on terrain surface has one degree of freedom while the internal point has two degrees of freedom. The slip surface is determined by four independent parameters. To find the desired four parameters, the procedure employs a certain influence matrix (found from sensitivity analysis), which accelerates the iteration process. The critical slip surface corresponds to the one with the lowest factor of safety.

After plotting the whole profile on the Geo4 the Factor of safety was checked for these following cases:

**Case 1:** When the slope is dry.

**Case 2:** When tension crack is filled with water.

**Case 3:** When slope is draining.

**Case 4:** When Cohesion is reduced to zero due to vibrations.

**Table 2:** Variation of minimum factor of safety at different cross-sections

Cross Section Distance	Case I	Case II	Case III	Case IV
0	1.38	0.54	0.77	0.57
3	1.25	0.81	0.71	0.51
6	1.16	0.72	0.67	0.49
9	1.15	0.67	0.67	0.45
12	1.12	0.66	0.66	0.51
15	1.15	0.68	0.69	0.50
18	1.21	0.70	0.71	0.49
21	1.21	0.71	0.69	0.48
24	1.26	0.79	0.72	0.50
27	1.46	1.01	0.83	0.55
30	1.60	1.40	1.58	1.02

### Introduction to PLAXIS

PLAXIS is a special purpose two-dimensional finite element computer program used to perform deformation and stability analyses for various types of geotechnical applications. Real situations may be modeled either by a plane strain or an axisymmetric model. The program uses a conventional graphical user interface that enables users to quickly generate a geometry model and finite element mesh based on a representative vertical cross-section of the situation at hand.

PLAXIS Version 8 may be used to carry out two-dimensional finite element analyses. Finite element models may be either *Plane strain* or *Axisymmetric*. Separate PLAXIS programs are available for 3D analyses. The default setting of the *Model* parameter is *Plane-strain*.

A *Plane strain* model is used for geometries with a (more or less) uniform cross section and corresponding stress state and loading scheme over a certain length perpendicular to the cross section (z-direction). Displacements and strains in z-direction are assumed to be zero. However, normal stresses in z direction are fully taken into account [22–30].

An *Axisymmetric* model is used for circular structures with a (more or less) uniform radial cross section and loading scheme around the central axis, where the deformation and stress state are assumed to be identical in any radial direction. Note that for axisymmetric problems the x-coordinate represents the radius and the y-coordinate corresponds to the axial line of symmetry. Negative x-coordinates cannot be used. The selection of *Plane strain* or *Axisymmetric* results in a two dimensional finite element model with only two translational degrees of freedom per node (x- and y-direction).

Analysis using PLAXIS is also done for different cases:

Case 1: When the slope is dry.

Case 2: When tension crack is filled with water.

Case 3: When slope is draining.

Case 4: When Cohesion is reduced to zero due to vibrations.

Case 5: Simulation of dynamic loading whose Accelerogram is given in the figure below.

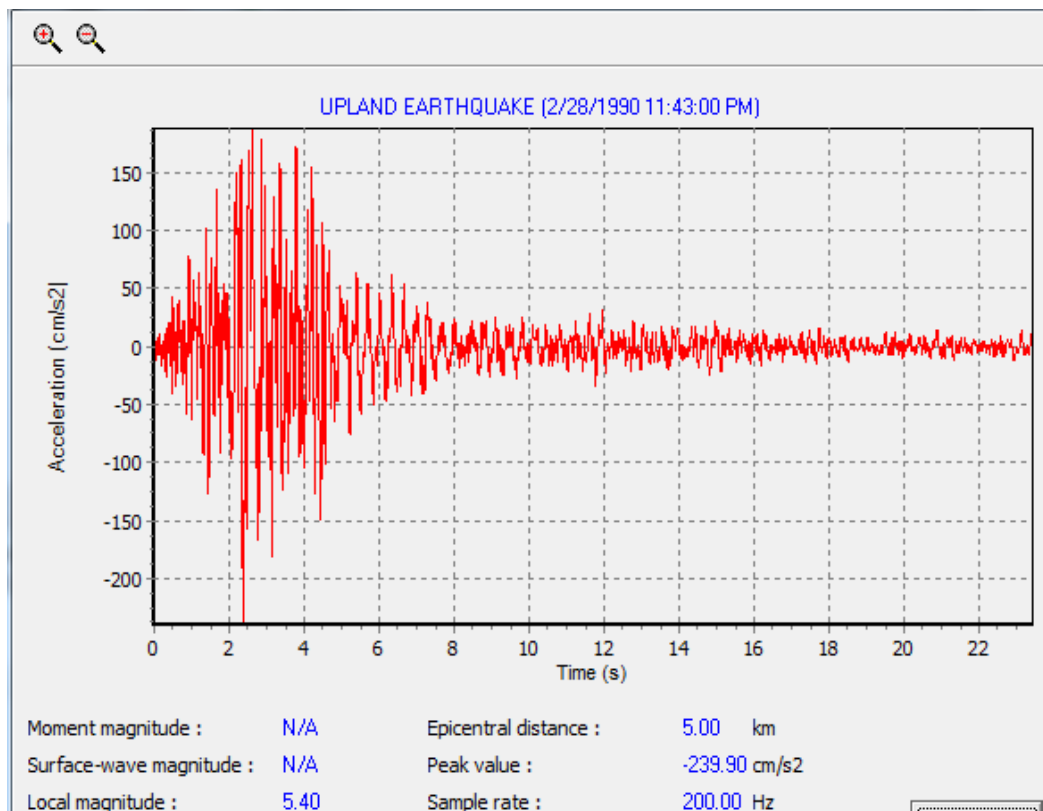

Fig. 4: Accelerogram.

Various factors of safety are calculated using PLAXIS are done



**Table 3: Variation of Minimum Factor of Safety at Different Cross-sections.**

Cross Section Distance	Case I	Case II	Case III	Case IV	Case V
0	1.289	0.543	0.707	0.426	0.410
3	1.162	0.831	0.617	0.41	0.406
6	0.96	0.795	0.612	0.391	0.380
9	1.034	0.588	0.460	0.395	0.398
12	0.915	0.662	0.559	0.551	0.527
15	0.924	0.662	0.553	0.400	0.410
18	1.267	0.721	0.726	0.401	0.401
21	1.101	0.724	0.592	0.389	0.390
24	0.933	0.846	0.603	0.376	0.376
27	1.277	0.913	0.761	0.383	0.367
30	2.157	1.981	1.15	0.889	0.885

For Most Critical Section We the Profile Section was as:

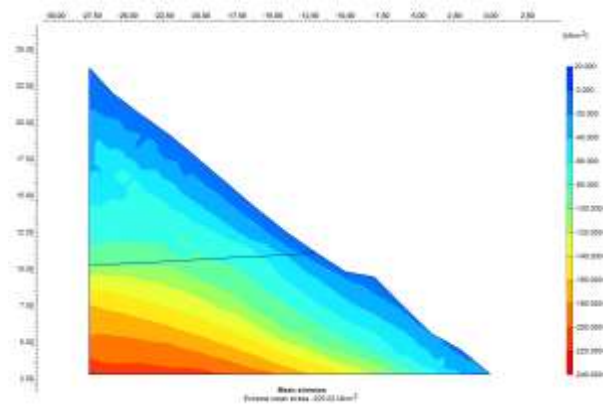
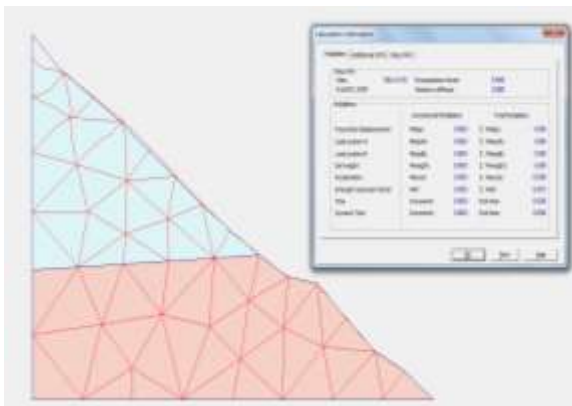

Case 1

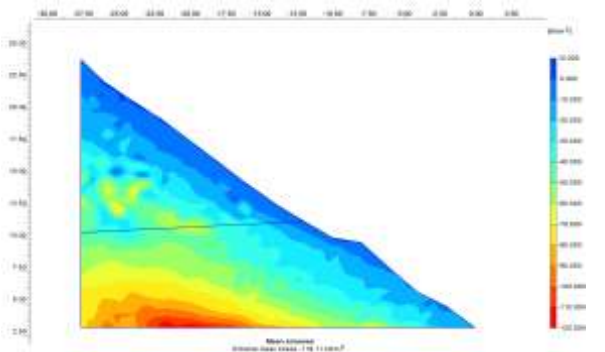
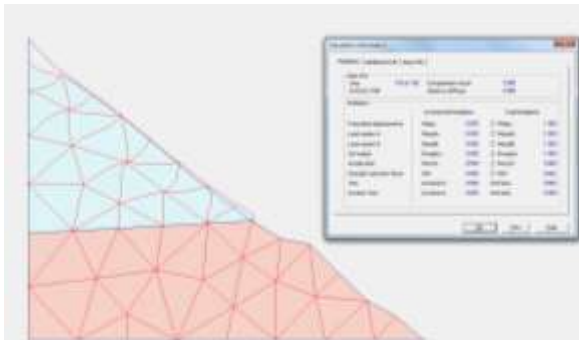

Case 2

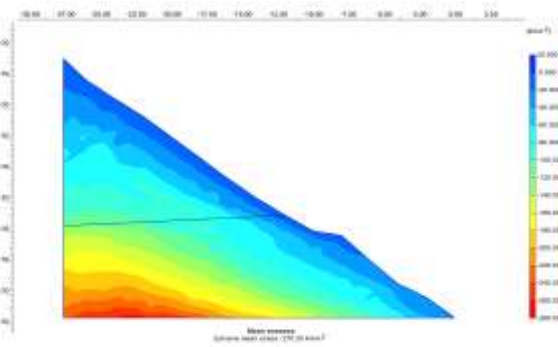
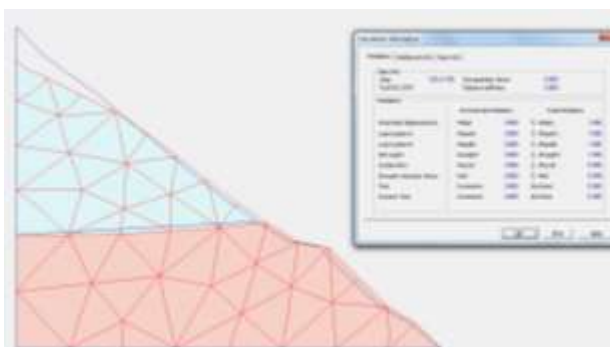

Case 3

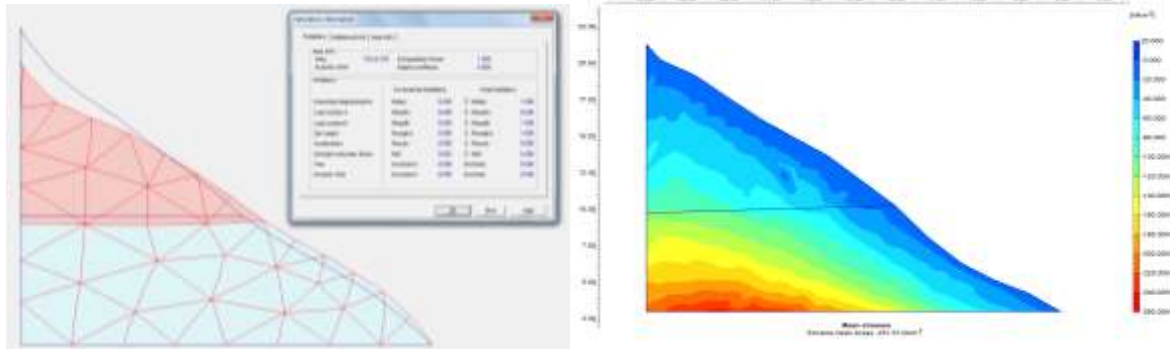

Case 4

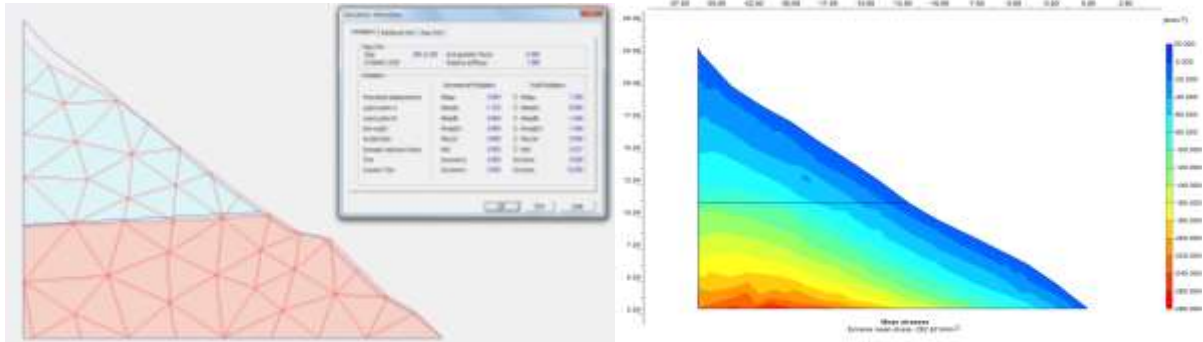

Case 5

**REMEDIAL MEASURES**

**Introduction**

Once the slope geometry and subsoil conditions have been determined, the stability of a slope may be assessed using either published chart solutions or a computer analysis. This portion reviews the mechanics of the limit equilibrium approach discussing the classical closed-form solutions as well as the popular method of slices.

**Modes of Failure**

These usually take the form of either: (1) Translational. (2) Plane or wedge surface, (3) Circular, or (4) Noncircular or a combination of these types. The aspect ratio used to differentiate between the translational and rotational surfaces is shown in Figure 2. With this definition a "grey" area where  $0.1 < D/L < 0.15$  has been left to account for the case of a combined rotational and translational failure [29–32].

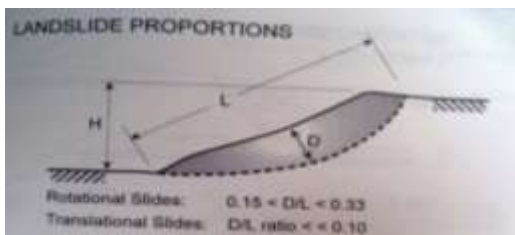

In our case, for critical section  $D=5.510\text{m}$  and  $l= 36.124\text{m}$ , Therefore  $L/D$  ratio is  $.152$   
Hence our failure mode is circular.

**Slope Stabilization Method**

Slope stabilization methods generally reduce driving forces, increase resisting forces, or both. Driving forces can be reduced by excavation of material from the appropriate part of the unstable ground and drainage of water to reduce the hydrostatic pressures acting on the unstable zone. Resisting forces can be increased by:

1. Drainage that increases the shear strength of the ground.
2. Elimination of weak strata or other potential failure zones.
3. Building of retaining structures or other supports.
4. Provision of in situ reinforcement of the ground.
5. Chemical treatment (hardening of soils) to increase shear strength of the ground.
6. Various methods were thought while considering the problem like:
7. Soil Nailing
8. Stone Columns
9. Reticulated Micro piles
10. Geosynthetically Reinforced method



Each with unique properties, advantages and disadvantages for this kind of soil strata. Geosynthetically reinforced method was used to finally reinforce the slope [33–41].

### Design of Geosynthetically Reinforced Wall

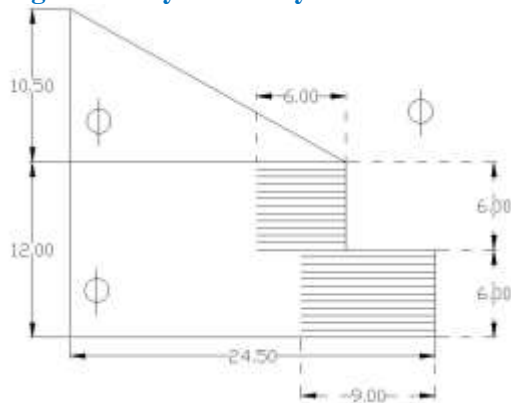

Fig. 5: Drawing of the Reinforced Slope.

#### Parameters

$\phi_w = 35^\circ$ ;  $\gamma_w = 18 \text{ kN/m}^3$ ;  $\phi_b = 21.15^\circ$ ;  
 $\gamma_b = 18.08 \text{ kN/m}^3$ ;  $k_w = .271$ ;  $\mu = 0.5$ ;  $k_b = .47$ ;  
 $\alpha = 0.9$ ;  $\beta = 45^\circ$ ;  $-\phi_b/2 = 34.425^\circ$   
Geogrid used T 90.

#### For wall 1

##### External stability

(a) Sliding: 
$$F_s = \frac{\mu(\gamma_w H L + qL)}{0.5 K_{Ab} \gamma_b H^2 + K_{Ab} qH}$$

Taking  $F_s = 2$  we get,  $L = 5.65 \text{ m}$   
Hence take  $L = 6 \text{ m}$

##### (b) Overturning:

$$F_o = \frac{3(\gamma_w H + q)}{K_{Ab}(\gamma_b H + 3q)(H/L)^2}$$

where,  $F_o$  must be greater than or equal to 2

After calculation we get,  $F_o = 3.445$

Hence, safe against overturning.

(c) For Tilting or Bearing:

$$\sigma_{\max} = (\gamma_w H + q) + K_{Ab}(\gamma_b H + 3q)\left(\frac{H}{L}\right)^2$$

$$\sigma_{\min} = (\gamma_w H + q) - K_{Ab}(\gamma_b H + 3q)\left(\frac{H}{L}\right)^2$$

$$\sigma_{\max} = 351.7856 \text{ kN/m}^2 \quad \sigma_{\min} = 24.21 \text{ kN/m}^2$$

#### Internal Stability

##### (a) Tension:

$$T_i = K_{Aw}[(\gamma_w h_i + q - 2c / \sqrt{K_{Aw}}) - K_{Ab}(\gamma_b h_i + 3q)\left(\frac{h_i}{L}\right)^2] \cdot S_{vi} \cdot S_{hi}$$

Here, after solving we get the equation as:

$$S_{vi} = 80 / (13.35 h_i + 134.4)$$

So, for different  $h_i$  corresponding  $S_{vi}$  are:

Table 4: Spacing at Different Elevations for Wall 1.

$h_i$	$S_{vi}$
0.2	0.58
1	0.54
2	0.496
3	0.458
4	0.425
5	0.397
6	0.372

We will provide grids for first 3m at a distance of 0.4m and for next 3m at a distance of 0.3m  
Hence total number of grids are =  $3/0.4 + 3/0.3 = 18$  grids

##### (b) Pullout:

$$T = \frac{h_i \tan \beta (\gamma_w h_i + 2q)}{2 \tan(\phi'_w + \beta)}$$

So for different  $h_i$  values we get corresponding T values:

Table 5: Pullout Strengths at Different Elevations for Wall 1.

$h_i$	T	No. of grids	T (average)
1	11.68	3	3.89
2	27.65	5	5.41
3	47.91	8	5.98
4	72.47	11	6.588
5	101.32	14	7.23
6	134.45	18	7.469

(c). **Anchorage:**

$$L_{ip} = \frac{T_i \cdot \text{Factor of safety}}{2\alpha \tan(\phi'_w)(\gamma_w h_i + q)}$$

From here we get  $L_{ip} = 0.60304$ .

Hence, the length of geo-grid will be = elevation from the base \*  $\tan\beta + L_{ip}$

**Table 6:** Length of Geogrids at Different Elevations for Wall 1.

Elevation	Length of Geogrid
6	1.137
5.7	1.411
5.4	1.685
5.1	1.959
4.8	2.233
4.5	2.507
4.2	2.781
3.9	3.055

**Calculations for Wall 2**

<b>3.6</b>	<b>3.2605</b>
<b>3.3</b>	3.466
<b>3</b>	3.6715
<b>2.6</b>	3.877
<b>2.2</b>	4.0825
<b>1.8</b>	4.288
<b>1.4</b>	4.4935
<b>1</b>	4.699
<b>0.6</b>	4.9045
<b>0.2</b>	5.11

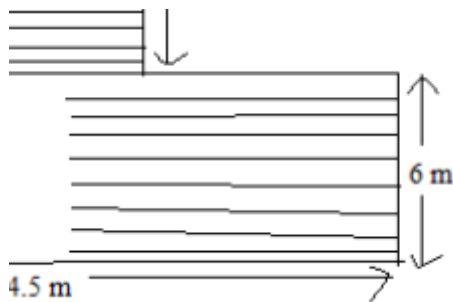

**Fig. 6:** Wall 2 Diagrammatically Shown.

(a) **Sliding:**

$$F_s = \frac{\mu(\gamma_w HL + qL)}{0.5 \cdot K_{Ab} \gamma_b H^2 + K_{Ab} qH}$$

Taking  $F_s = 2$  we get,  $L = 8.808$  m

Hence take  $L = 9$  m.

(d) **Overturning:**

$$F_o = \frac{3(\gamma_w H + q)}{K_{Ab}(\gamma_b H + 3q)(H/L)^2}$$

Where,  $F_o$  must be greater than or equal to 2

After calculation we get,  $F_o = 6.7687$

Hence safe against overturning.

(e) **For Tilting or Bearing:**

$$\sigma_{max} = (\gamma_w H + q) + K_{Ab}(\gamma_b H + 3q)\left(\frac{H}{L}\right)^2$$

$$\sigma_{min} = (\gamma_w H + q) - K_{Ab}(\gamma_b H + 3q)\left(\frac{H}{L}\right)^2$$

$$\sigma_{max} = 354.27 \text{ kN/m}^2 \quad \sigma_{min} = 136.53 \text{ kN/m}^2$$

**Internal Stability**

(c) **Tension:**

$$T_i = K_{Aw} [(\gamma_w h_i + q - 2c / \sqrt{K_{aw}}) - K_{Ab}(\gamma_b h_i + 3q)\left(\frac{h_i}{L}\right)^2] \cdot S_{vi} \cdot S_{hi}$$

Here after solving we get the equation as:

$$S_{vi} = 80 / (8.63h_i + 123.028)$$

So, for different  $h_i$  corresponding  $S_{vi}$  are:

**Table 7:** Spacing's at Different Elevations for wall 2.

$h_i$	$S_{vi}$
<b>0.2</b>	0.638193
<b>1</b>	0.604878
<b>2</b>	0.567827
<b>3</b>	0.535053
<b>4</b>	0.505855
<b>5</b>	0.47968
<b>6</b>	0.45608

We will provide grids for first 3m at a distance of 0.5m and for next 3m at a distance of 0.4m Hence total number of grids are=  $3/0.5 + 3/0.4 = 14$  grids

(d) **Pullout:**

$$T = \frac{h_i \tan \beta (\gamma_w h_i + 2q)}{2 \tan(\phi'_w + \beta)}$$

So for different  $h_i$  values we get corresponding T values.

**Table 8: Pullout Strengths at Different Elevations for Wall 2.**

$h_i$	T	No. of grids	T (average)
1	37.654	2	18.825
2	79.93	4	19.98
3	126.84	6	21.14
4	178.38	9	19.82
5	234.55	11	21.32
6	295.344	14	21.096

(e) **Anchorage:**

$$L_{ip} = \frac{T_i \cdot \text{Factor of safety}}{2\alpha \tan(\phi'_w)(\gamma_w h_i + q)}$$

Form here we get  $L_{ip} = 0.1419$

hence the length of geogrid will be = elevation from the base\*  $\tan\beta + L_{ip}$ .

**Table 9: Length of Geogrids at Different Elevations.**

Elevation	Length of geogrid
5.9	1.137
5.5	1.4795
5.1	1.822
4.7	2.1645
4.3	2.507
3.9	2.8495
3.5	3.1235
3.1	3.3975
2.7	3.6715
2.2	3.9455
1.7	4.2195
1.2	4.4935
0.7	4.7675
0.2	5.0415

**Table 10: Minimum Factor of Safety with Reinforced Earth Wall.**

	Case I	Case III	Case IV	Case V
<b>FOS</b>	3.003	2.488	1.964	1.964

Case II is not possible i.e. the case of undrained as proper drainage is provided as mentioned:

Provide 100 mm diameter perforated pipes for full length of slope at 1.5m center to center both horizontally and vertically inclined at an angle of 5° downwards.

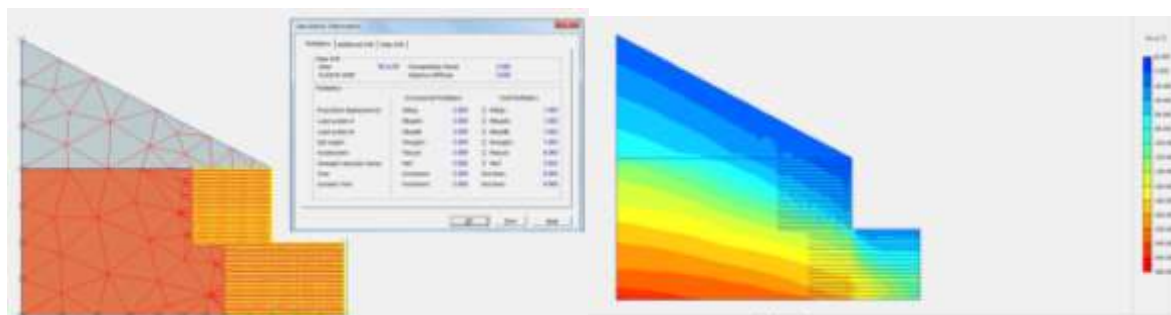

Case 1

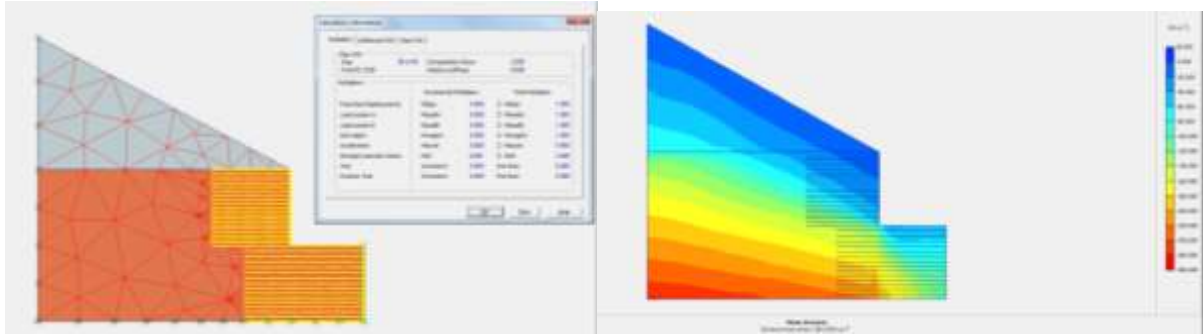

Case 3

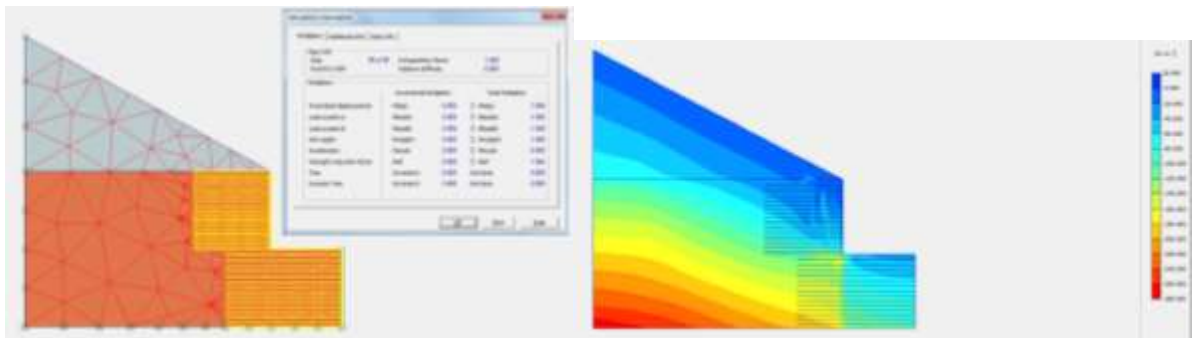

Case 4

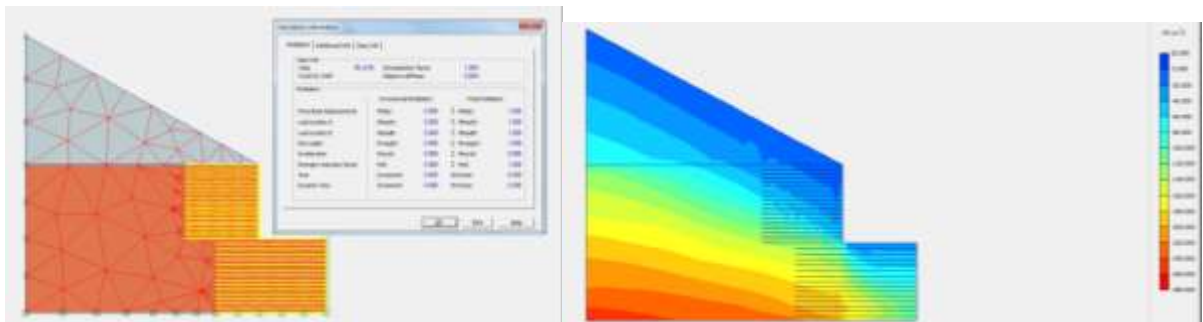

Case 5

**Estimation and Costing:**

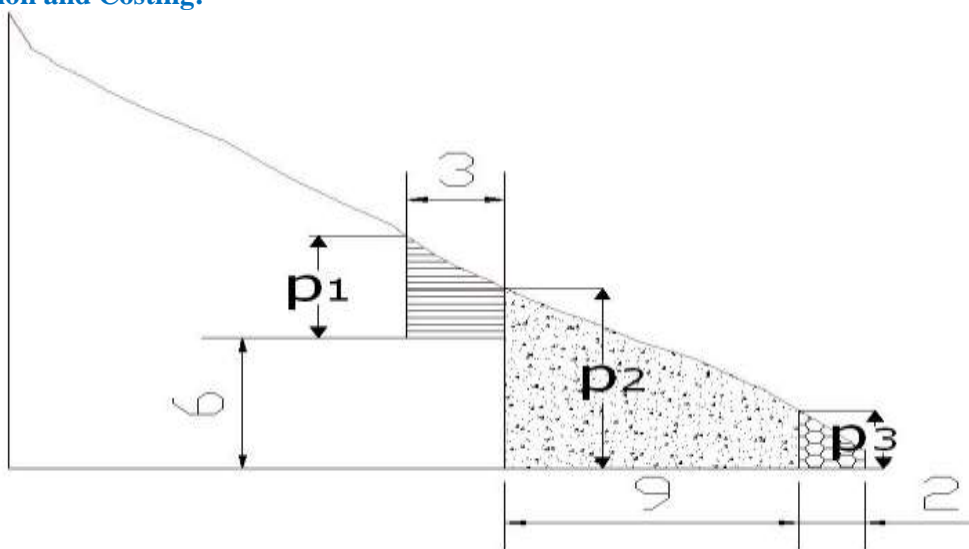

*Fig. 7: Land Excavated.*

### Excavation:

**Table 11:** Estimation Details.

Element of wall	P <sub>1</sub> (m)	P <sub>2</sub> (m)	P <sub>3</sub> (m)	H(m)	Z(m)	Volume(m <sup>3</sup> )
3m (0m to 6m)		9.6	1.3	6	6	196.2
6m (6m to 9m)		9.24	1	9	3	138.24
15m (12m to 18m)		8	3	9	6	297
24m (21m to 27m)		8.52	1.4	9	6	267.84
30m (27m to 30m)		9.6	1.3	6	6	196.2
6m (6m to 9m)	5.5	3.24		3	3	39.33
15m(12m to 18m)	4	2		3	6	54
24m(21m to 27m)	5	2.53		3	6	67.77
0m to 30m			2	2	30	60
Total						1206.24

### Costing:

**Table 12:** Costing Details.

Name of element	Volume excavated	Cost (per m <sup>3</sup> )	Premium	Total cost (Rs)
Excavation	1206 m <sup>3</sup>	90	1.65	179091.00
Wall material	2214m <sup>3</sup>	120	1.65	438372.00
Geogrid used	2943m <sup>2</sup>	600	1.3	2295540.00
Finishing and dressing material	10% of wall material	-	-	43837.20
Fascia element	306m <sup>2</sup>	1200	1.3	477360.00
Total cost				3434200.20

### REFERENCES

1. Fellenius W., Calculation of the stability of earth dams. *Transactions, 2nd International Congress on Large Dams, International Commission Large Dams* 1936:445–9.
2. Jiang YS., *Slope Analysis using Boundary Elements*. New York:Springer-Verlag Publishers; 1990.
3. Matsui T, San K., Finite element slope stability analysis by shear strength reduction technique. *Soils Foundation* 1992; 32: 59–70.
4. Jaritngam S, Chuchom S, Limsakul C, Jaritngam R. Slope stability analysis using neural networks. In: *The 6th Mining, Metallurgical and Petroleum Engineering Conference on Resources Exploration And Utilization For Sustainable Environment (Reuse)* 2001. 24–6p.
5. Janbu N. Application of composite slip surface for stability analysis. In: *Proceedings of European conference on stability of earth slopes*. Stockholm, Sweden 1954, 43–9p.
6. Janbu N., Slope stability computations. Institute for Geoteknik og Fundamental, Norges Tekniske Høgskole. *Soils Mechanic Sand Foundation Engineering*, The Technical University of Norway 1968.
7. Janbu N., *Slope Stability Computations*. In: Hirschfield E, Poulos S, Eds. *Embankment dam engineering (Casagrande memorial volume)* New York: John Wiley; 1973. 47–86p.
8. EM 1110-2-1902. *Stability of Earth and Rock-Fill Dams*. US army engineer waterways experiment station. Vicksburg 1970.



9. Lowe J, Karafiath L. Stability of earth dams upon drawdown. In: *Proceedings of the First Pan-American Conference on Soil Mechanics and Foundation Engineering* 1960; 2: 537–52p.
10. Taylor DW. *Stability of Earth Slopes*. J. Boston Soc Civil Engineers 1937; 24: 197–247. Reprinted in: Contributions to Soil Mechanics; 1925–1940p, *Boston Society of Civil Engineers* 1940. 337–86p.
11. Bishop AW. The use of the slip circle in the stability analysis of slopes. *Geotechnique* 1955; 5: 7–17p.
12. Morgenstern NR, Price VE. The analysis of the stability of general slip surfaces. *Geotechnique* 1965; 15: 79–93p.
13. Spencer EE., A method of analysis of the stability of embankments assuming parallel interslice forces. *Geotechnique* 1967; 17: 11–26p.
14. Spencer EE., The thrust line criterion in embankment stability analysis. *Geotechnique* 1973; 23: 85–100.
15. Sarma SK., Stability analysis of embankments and slopes. *Geotechnique* 1973; 23: 423–33.
16. Sarma SK. Stability analysis of embankments and slopes. *J Geotechnical Engineering Division* 1979; 105: 1511–24p.
17. Duncan JM., State of the art: limit equilibrium and finite element analysis of slopes. *J Geotechnical Engineering* 1996; 122: 577–96p.
18. Greco VR, Gulla` G. Slip surface search in slope stability analysis. *Riva Italy Geotechnical* 1985; 19(4): 189–98p.
19. Celestino TB, Duncan JM., Simplified search for non-circular slip surface. In: *Proceedings of the 10th International Conference on Soil Mechanics and Foundation Engineering* 1981. 391–4p.
20. Li KS, White W. Rapid evaluation of the critical slip surface in slope stability problems. *Int J Numer Anal Methods Geomechanics* 1987; 11: 449–73p.
21. Baker R. Determination of the critical slip surface in slope stability computations. *International Journal of Numerical Analysis Methods in Geomechanics* 1980; 4: 333–59p.
22. Chen Z. Random trials used in determining global minimum factors of safety of slopes. *Can Geotech J* 1992; 29: 225–33p.
23. Nguyen V., Determination of critical slope failure surfaces. *Journal of Geotechnical Engineering* 1985; 111: 238–50p.
24. Greco VR., Efficient Monte-Carlo technique for locating critical slip surface. *Journal of Geotechnical Geoenvironmental Engineering* 1996; 125: 301–8p.
25. Husein Malkawi AI, Hassan WF, Abdulla F., Uncertainty and reliability analysis applied to slope stability. *Structural Safety J* 2000; 22: 161–87.
26. Husein Malkawi AI, Hassan WF, Sarma SK. Global search method for locating general slip surface using Monte Carlo techniques. *Journal of Geotechnical Geoenvironmental Engineering* 2001; 127: 688–98p.
27. Husein Malkawi AI, Hassan WF, Sarma SK. An efficient search method for locating circular slip surface using Monte Carlo technique. *Can Geotech J.* 2001; 38: 1081–9p.
28. [28] HuseinMalkawi AI, Hassan WF, Sarma SK. Closure to discussion of a global search method for locating general slip surface using MonteCarlo techniques. By Gautam Bhattacharya. *J. Geotech Geoenviron. Eng.* 2002; 128: 1050p.
29. HuseinMalkawi AI, Hassan WF, Sarma SK. Reply to discussion of an efficient search method for locating circular slip surface using Monte Carlo technique, by V.R. Greco. *Canadian Geotechnical Journal* 2003; 40: 221–2p.
30. [30] Swan CC, Seo Y., Limit state analysis of earthen slopes using FEM approaches. *International Journal of Numerical Analysis Methods in Geomechanics* 1999; 23: 1359–71.
31. Griffiths DV, Lane PA. Slope stability analysis by finite elements. *Geotechnique* 1999; 49: 387–403p.
32. Brinkgreve RBJ, Vermeer PA., *Plaxis 3D Tunnel* Tokyo, Balkema Publishers 2001.
33. Whitman RV, Bailey WA. Use of computers for slope stability analysis. *Journal of Soil Mechanics Foundation ASCE* 1967; 93: 475–98p.
34. Chowdhury RN, Zhang S. Convergence aspect of limit equilibrium methods for slopes. *Canadian Geotechnical Journal* 1990; 27: 145–51p.

35. Wright SG. *A Computer Program for Slope Stability Calculations*. Austin (TX): Shinhoak Software; 1991.
36. Pockoski M, Duncan JM. *Comparison of Computer Programs for Analysis of Reinforced Slopes*. Virginia Polytechnic Institute and State University 2000.
37. Indian Standard Methods of test for soils- IS:2720 (Part II) 1973.
38. Indian Standard Methods of test for soils (Part I)-*Grain Size Analysis* (Second Revision)-IS:2720 (Part IV)-1985.
39. Determination of liquid limit by Casagrande apparatus-IS: 9259–1979p.
40. Soil Test-IS: 2720 Part II-1969.
41. Methods of test for soils, *Direct Shear Test*-IS: 2720 (Part 13).